

# ROBUS®

## LIGHTING CONTROLS

### LOADPRO 250W LED GRID DIMMER

250W, IP20



## PRODUCT INFORMATION DOCUMENT

### CONSTRUCTION

- Polycarbonate housing
- Large screw terminals
- Min and Max level adjustment knobs

### FEATURES

- Compatible with most of ROBUS dimmable luminaires (compatibility list available on the website)
- Compatible with MK Logic, Schneider, Hamilton, BG, Crabtree, DETA, Hager and Wandsworth grid systems
- Equipped with overload protection for enhanced security
- Suitable for one and two way switching



WARRANTY



LIFETIME



IP RATING



OPERATING VOLTAGE



SAFETY CLASS



DIMMING

	RLA250DTG-01
Maximum LED Load (W):	250
Minimum LED Load (W):	5
IP:	20
Operation Temperature (°C):	-10 ≤ Ta ≤ +40
Dimensions LxWxH	59x26x44
Weight (kg):	0.03

Product is certified to all the relevant standards.

Please contact our technical department for market specific compliances.

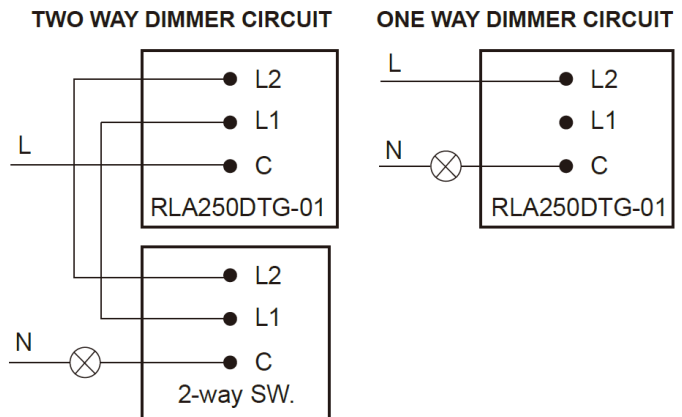

PLEASE NOTE: INFORMATION IN THIS DOCUMENT MAY BE SUBJECT TO CHANGE WITHOUT PRIOR NOTICE

IRE: TEL: +353 1 709 9000  
 UK: TEL: 0800 973 220  
 AUS: TEL: +61 7 3890 5444  
 NZ: TEL: +64 03 668 5285

WEB: ROBUS.COM  
 WEB: ROBUS.COM  
 WEB: ROBUS.COM.AU  
 WEB: ROBUSLED.CO.NZ

LED GROUP EUROPE · AUSTRALIA · NEW ZEALAND · ASIA · MIDDLE EAST · AFRICA